

# 2010 ANSYS SOUTH AMERICAN CONFERENCE & ESSS USERS MEETING

October 19-22 - Atibaia, SP - Brazil

## Application of ANSYS in the Simulation of IEC Type Tests Applied to Low and Medium Voltage Switchboards



# MSO INDUSTRIAL

Soluciones Avanzadas de Ingeniería

- MSO Industrial offers Specialized technical advice for the optimization of industrial processes and manufactured products with the use of Computer Assisted Engineering (CAE)
- Our capabilities are based in four core competences:
  - Thermal and Structural optimization.
  - Multiphysics analysis.
  - Rational use of energy.
  - Applied research and development

## SERVICES:

### CONSULTANCY SERVICES

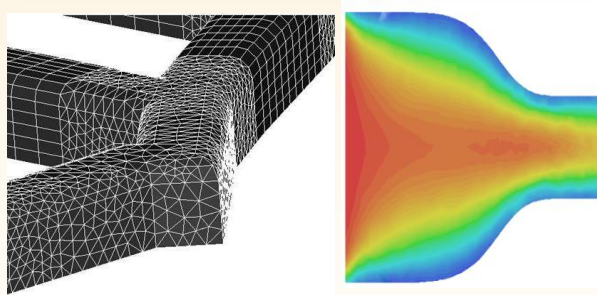

- Structural
- Thermal
- Fluid dynamics
- Electrodynamics
- Optimization

### PRODUCT DEVELOPMENT

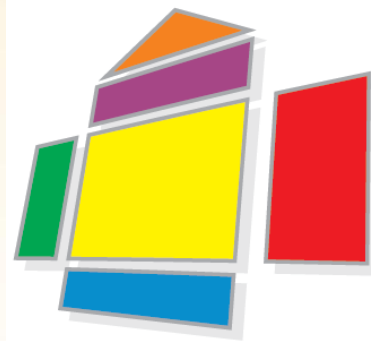

- Concurrent engineering
- Functional analysis
- Design for assembly / manufacturability
- Quality analysis
- AMFE / QFD

### RATIONAL USE OF ENERGY



ISO 50001: 2010

- Energy management
- Continuous improvement
- Thermal optimization
- Transversal or particular evaluation.



### INTEGRAL SIMULATION TOOLS SUPPLY



**ESSS**  
ENGINEERING SIMULATION  
SCIENTIFIC SOFTWARE

- Software supply
- Support
- Training
- Project development



## PROBLEM DESCRIPTION

- The IEC requires type test for temperature rise, short circuit and arc flash for low and medium voltage switchgears and controlgears.
- In Colombia there are no labs with the required capacity to execute this kind of test.
- This restriction adds limitations to certifications process, increasing time and costs for the development of new products.



### Common costs of type tests

- 2 Prototypes: U\$ ~12.000
- Logistics: U\$ ~3.000
- Labs tests: U\$ ~40.000
- **TOTAL AVE: U\$ ~ 55.000**

Time for Results: **3 Months**  
(In best case)

# OBJECTIVES

---

- Verify by means of simulation the accordancy of switchgears and controlgears, during IEC type test for temperature rise, short circuit and arc flash.
- Increase the likelihood of success of the switchboards during the execution of type tests in the labs.
- Speed up the development and certification process of colombian manufacturers of switchboards.
- Decrease the cost of development of new products.

# METHODOLOGY - General

- Based on the requirements of the IEC standards, a comparative analysis is made between the expected results and the simulated results.

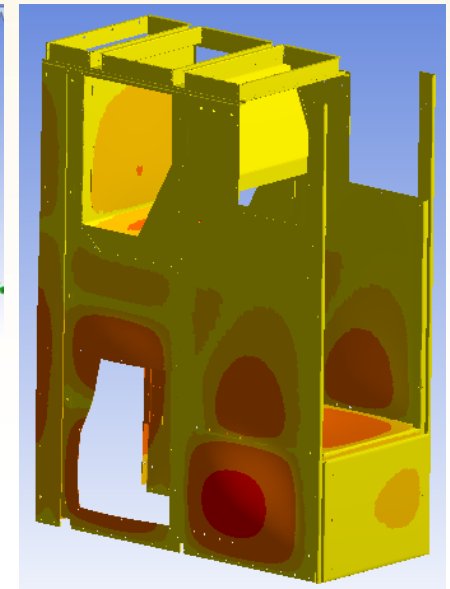
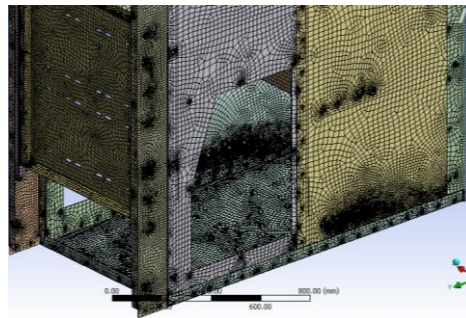
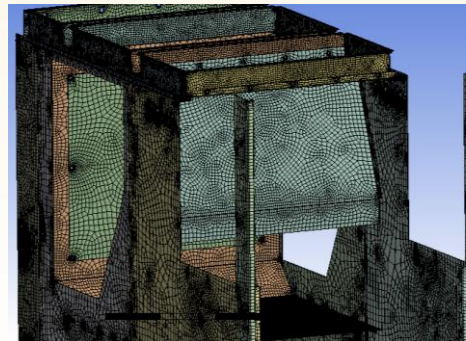
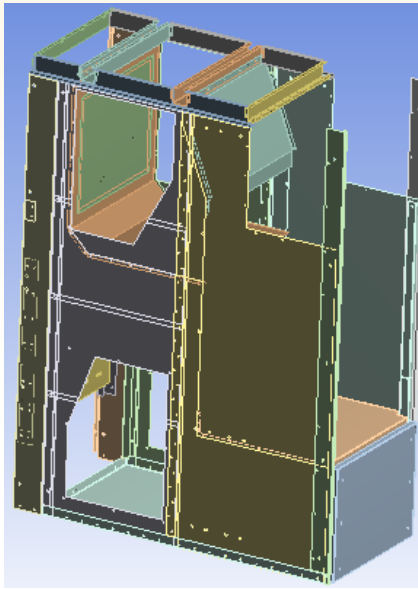

# METHODOLOGY – Short Circuit type test

---

## Reference standars

- IEC-60865
- IEC-60439 1 and 2 Num 7.5 / NTC 3475
- IEC 62271 Num 6.6 / NTC-3309

## Applied physics (ANSYS Modules)

- Electromagnetic (steady or transient): Joule effect.
- Thermal (steady or transient): Heat transfer coefficient, Temperature field.
- Structural (static or transient): Non Linear materials, thermal deformations.

# METHODOLOGY – Short Circuit type test

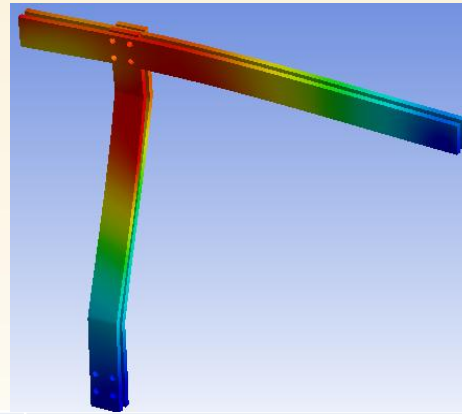
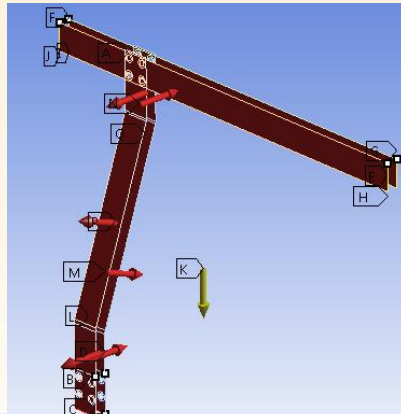

	NORMATIVE REQUIREMENTS	SIMULATION VERIFICATION
<b>BEFORE TEST</b>	Representative prototype	3D CAD
	Normal operating conditions	Normal operating conditions
	Controlled conditions	No variation in conditions (Ideal conditions)
<b>AFTER TEST</b>	Structural	No plastic deformations
	Electrical	No way to evaluate this now
	Thermal	No metal melting or softening temperature

# METHODOLOGY- Temperature rise

---

## Reference standars

- IEC-60439 1 & 2 Num 7.5
- IEC 62271 Num 6.5

## Applied physics (ANSYS Modules)

- Electromagnetic (steady): Joule effect.
- Thermal (steady): Temperature field in busbars and panels.
- CFD (steady): Heat transfer coefficient calculation.

# METHODOLOGY- Temperature rise

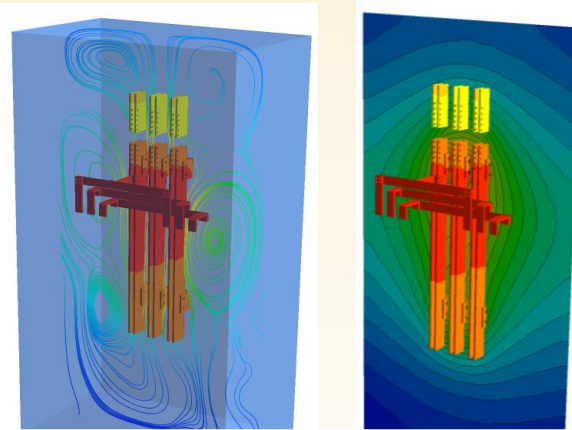

	NORMATIVE REQUIREMENTS	SIMULATION VERIFICATION
<b>BEFORE TEST</b>	Representative prototype	3D CAD
	Normal operating conditions	Normal operating conditions
	Controlled conditions	No variation in conditions (Ideal conditions)
<b>AFTER TEST</b>	Structural	N/A
	Thermal	No temperature limit violation
	Electric	Efficiency and power loss

# METHODOLOGY- Arc Flash (Over-pressure and gas evacuation)

---

## Reference standars.

- IEC-60439 1 and 2 Num 7.5 / NTC 3475
- IEC 62271 Num 6.5 / NTC 3309

## Applied physics (ANSYS Modules)

- Electromagnetic (transient): Joule effect.
- Thermal (transient): Temperature field in busbars and panels.
- Structural (Steady or transient): Deformations due to pressure wave.
- CFD (transient): Heat transfer coefficient calculation, gas evacuation simulation.

# METHODOLOGY- Arc Flash (Over-pressure)

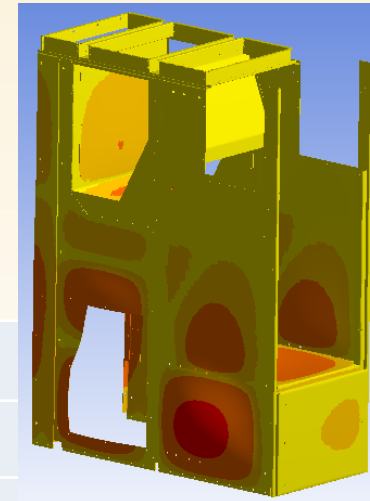
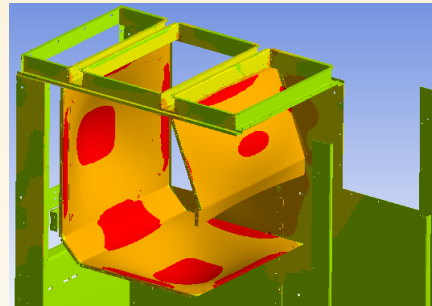
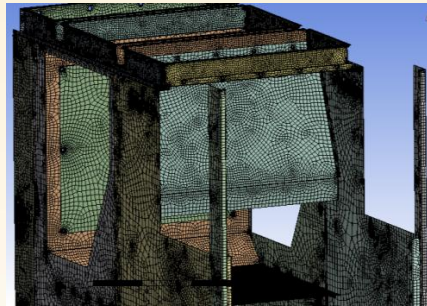

	NORMATIVE REQUIREMENTS	SIMULATION VERIFICATION
<b>BEFORE TEST</b>	Representative prototype	3D CAD
	Normal operating conditions	Normal operating conditions
	Controlled conditions	No variation in conditions (Ideal conditions)
<b>AFTER TEST</b>	Structural	No debris after detonation
	Thermal	No temperature limit violation
	Electric	Efficiency and power loss
	Fluids	Gas evacuation and pressure wave values

# ACHIEVEMENTS

---

- Improvement of the development process of new products for the electrical sector industries, faster and confident.
- Open discussion between the manufacturers and regulators about the opportunities, risks and benefits of simulation in the development of new products.
- Collaborative work with certification entities and local manufacturers of electrical products.

# CONCLUSIONS

---

- It is possible to simulate the three type test shown here getting deeper results before real lab tests.
- It is necessary to standardize this process in order to facilitate the evaluation of results.
- It is necessary to involve the regulation bodies in the definition of the scope of the simulation of IEC type tests.

## NEXT STEPS

---

- Implementation CFD models for the evacuation of gas during arc flash events.
- Validation of the results with primary source data for the three types of tests (currently we use secondary source).
- Implementation of the procedure as a design by analysis tool (i.e. ASME Section VIII div 3). Project for Colombian the electric cluster.

TANK YOU - GRACIAS - OBRIGADO



**SOLUCIONES AVANZADAS DE INGENIERÍA**

[msoindustrial@msoindustrial.com](mailto:msoindustrial@msoindustrial.com)

[www.msoindustrial.com](http://www.msoindustrial.com)

**MSO Industrial S.A.S.**

**+(574) 262-38-66**

**C. Cial. Automotriz - Cra 43ª No 19ª-87 Of. 218**

**Medellín, Colombia**

